

RISER PAD - ASSEMBLY PIECES

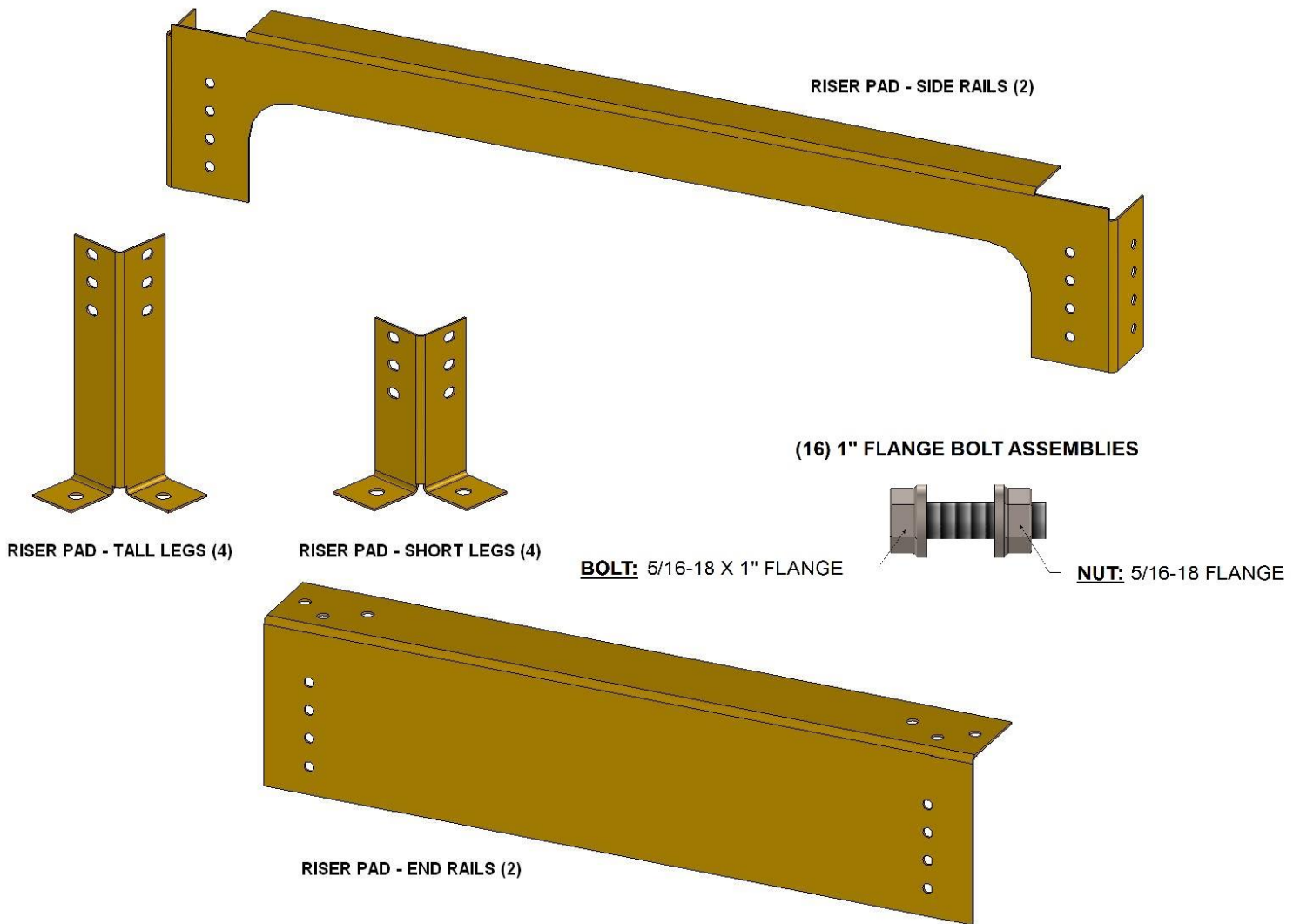

FIRST ASSEMBLE TWO (2) SIDES (As shown in figure #1)

Attach two (2) legs to a riser pad side rail at the desired pad height, using four (4) 1" bolt assemblies.



Figure #1

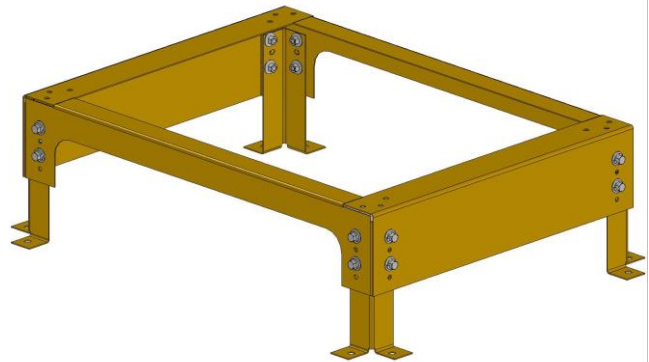

Figure #2

THEN COMPLETE THE RISER PAD PADS (As showing in figure #2)

Connect the two (2) side rail assemblies using two (2) riser pad end rails with eight (8) 1" flange bolt assemblies.